

72" RESTAURANT RANGES

 GAS TYPE: NATURAL LP

- | | | |
|------------------------------------|-------------------------------------|------------------------------------|
| <input type="checkbox"/> AR-12 | <input type="checkbox"/> AR-12G-10B | <input type="checkbox"/> AR-24G-8B |
| <input type="checkbox"/> AR-36G-6B | <input type="checkbox"/> AR-48G-4B | <input type="checkbox"/> AR-60G-2B |
| <input type="checkbox"/> AR-72G | | |

STANDARD FEATURES

- Commercial gas range 72" wide and 32 1/2" depth
- Cooking height 36"
- Stainless steel sides, front, and 6" deep front landing ledge
- Adjustable 6" legs
- Choose: 6" high stainless steel stub back, high riser, or high riser with shelf at no charge
- Two year limited warranty, parts, and labor
- Base options: Standard, convection, or storage base

OPEN BURNERS

- 12" x 12" cast-iron top grates
- 32,000 BTU/hr. lift-off open burners
- Removable full width drip pan under burner

STANDARD OVEN *(Two Standard 26 1/2" Ovens)*

- Steel oven burner rated at 35,000 BTU/hr.
- Oven dimensions: 26 1/2"W x 22 1/2"D x 13 1/2"H
- Thermostat ranging from 250°F to 500°F (121°C to 260°C)
- Oven Door: Spring assisted, counterweight door
- Two chrome plated oven racks (Additional racks optional)
- Two fixed rack positions
- Porcelain enamel oven interior for easy cleaning
- 100% safety gas shut off

CONVECTION OVEN *(In place of standard oven)*

- Steel oven burner rated at 30,000 BTU/hr.
- Convection oven fan improves heat transfer for a faster cook time
- Thermostat ranging from 250°F to 500°F (121°C to 260°C)
- Two chrome plated oven racks (Additional racks optional)
- Chrome rack guides with five tray positions

GRIDDLES

- 1" thick steel griddle plate
- 3" wide grease collector
- One burner every 12", rated at 20,000 BTU/hr.
- Manual control valve for each burner
- Optional : Thermostatic griddle with modulating thermostat

AVAILABLE OPTIONS

- Swivel Casters (Set of four – two with front brakes)
- Storage Cabinet Base (In place of standard oven)
- Thermostatic Control Griddle



Model Shown AR-12

Shown with optional casters

DESCRIPTION

American Range, restaurant range size 72" x 32-1/2" x 56" Stainless steel front, sides, backriser, shelf, and 6" adjustable legs. Removable full width drip pan. Choose 32,000 BTU/hr. open burners with no-clog lift-off burner heads or 20,000 BTU/hr. 12" section griddle or a combo burner griddle. Griddle comes standard on left. Heavy-duty cast iron grates, 12" x 12". Burner knobs are cool to the touch, high temperature material. Two ovens: 35,000 BTU/hr. standard oven, or 30,000 BTU/hr. for convection with porcelain interior and inside door panel, oven interior measures 26-1/2"W x 22-1/2"D x 13-1/2"H. Oven thermostat adjusts from 250°F to 500°F. All ovens supplied with two racks. Oven door with a spring assisted, counterweight mechanism requiring no adjustment. Rear gas connection and pressure regulator.



72" RESTAURANT RANGES with two 26 1/2" ovens

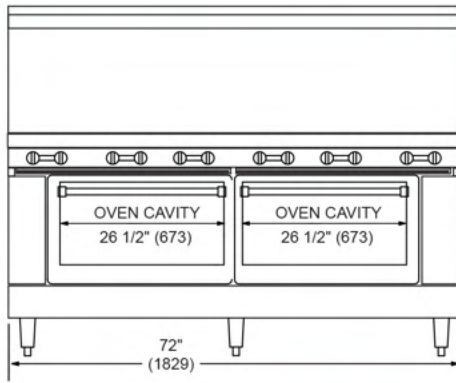

Front Oven Base

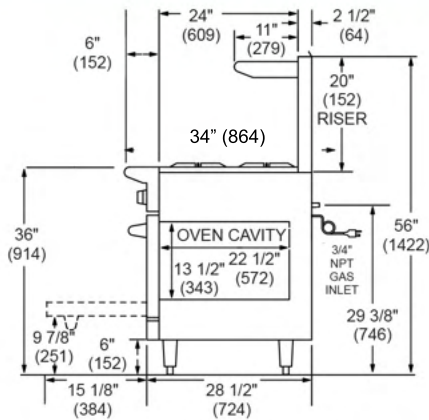

Side Standard Oven Base

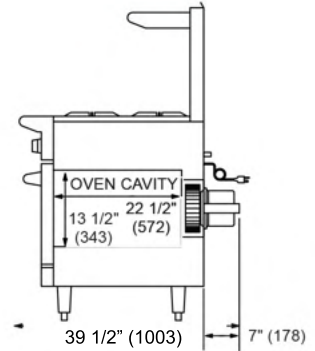

Side Convection Oven

TOP	MODEL	BTU/hr.	(KW)	BURNERS	GRIDDLE SIZE	Shipping Weight*	
						LBS	(KG)
	AR-12	454,000	(133)	12	N/A	810	(367)
	AR-12-CC	444,000	(131)	12	N/A	956	(434)
	AR-12-DSB	384,000	(113)	12	N/A	670	(290)
	AR-24G-8B	366,000	(108)	8	24" (610 MM)	840	(381)
	AR-24G-8B-CC	420,000	(124)	8	24" (610 MM)	986	(447)
	AR-24G-8B-DSB	296,000	(87)	8	24" (610 MM)	700	(318)
	AR-36G-6B	322,000	(95)	6	36" (914 MM)	855	(388)
	AR-36G-6B-CC	312,000	(92)	6	36" (914 MM)	1001	(454)
	AR-36G-6B-DSB	252,000	(74)	6	36" (914 MM)	715	(324)
	AR-48G-4B	278,000	(82)	4	48" (1219 MM)	870	(395)
	AR-48G-4B-CC	268,000	(79)	4	48" (1219 MM)	1016	(461)
	AR-48G-4B-DSB	208,000	(61)	4	48" (1219 MM)	730	(331)
	AR-72G	190,000	(56)	N/A	72" (1524 MM)	900	(408)
	AR-72G-CC	180,000	(53)	N/A	72" (1524 MM)	1046	(474)
	AR-72G-DSB	120,000	(35)	N/A	72" (1524 MM)	760	(345)
	With (2) Standard Ovens Only						
	AR-60G-2B	234,000	(69)	2	72" (1524 MM)	885	(401)

“C” = Convection Oven, “SB” = Storage Base, “G” = Manual Griddle Top.
 Griddle on the left, storage base on the right.
 Combo Base options available - choose standard, convection ovens, or storage base.
 Contact factory for other options.
 Griddle comes standard on the left. Special order griddle on the right.

COMBUSTIBLE WALL CLEARANCES: For use only on noncombustible floors. Legs or casters are required, or 2" (51) overhang is required when curb mounted. Clearance from non-combustible walls is 0". When unit is placed next to combustible walls, clearances must exceed 12" (305) from sides, and 4" (102) from rear. Commercial cooking equipment requires an adequate ventilation system. For additional information, refer to the National Fire Protection Association's standard, NFPA96 "Vapor Removal from Cooking Equipment." (NOTE: For North America only)

CONVECTION OVEN ELECTRICAL		
VOLTAGE	PHASE	AMPS
120	1	4

15 amps three prong cord provided

MANIFOLD PRESSURE		
NATURAL GAS	PROPANE GAS	MANIFOLD SIZE
5.0" W.C.	10.0" W.C.	3/4" (19MM)

Specify type of gas and altitude if over 2000 feet. Please specify gas type when ordering.

*Shipping weight includes packaging and is approximate.

