

AMERICAN RANGE®

A  Company

Project _____

Item # _____

Quantity _____

GAS CONVECTION OVEN

GAS TYPE: NATURAL LP



MSD-1HE

MSD-2HE

STANDARD FEATURES

- Standard depth models 54,000 BTU/hr. total heat output per oven
- All stainless steel front, sides and top
- 50/50 dependent double door, swings open 135°, one handed operation opens and closes both doors simultaneously
- Door options:
 - Two glass doors (GG)
 - Glass door, right (GL)
 - Glass door, left (GR)
 - Two solid doors (SS)
- Porcelain oven interior for easy cleaning
- Five chrome racks with 12 position chrome rack guides
- Oven cavity accommodates a full size sheet pan horizontally on standard depth models
- Electronic spark igniter
- 1/2 H.P. two speed oven blower motor with
- maximum of 9 amp draw. Includes 6 foot power cord
- Oven cool switch for rapid cool down
- Burner "on" light
- 1 hour timer
- Thermostat control from 200°F to 500°F (93°C to 260°C)

OPTIONAL FEATURES

- 208/240 V motor and/or transformer
- Direct vent adapter
- Casters



Model Shown MSD-1HE
(Standard Depth)

DESCRIPTION

American Range, model MSD-1HE single or MSD-2HE double, standard depth convection oven with 54,000 BTU/hr., temperature range from 200°F to 500°F. A half horsepower fan offers low and high speed fan options for baking and roasting. Porcelain oven cavity includes a 12 position rack guide to accommodate five chrome racks which will hold 18" x 26" sheet pans horizontally or 12" x 20" hotel pans one per rack. The oven includes a 1 hour timer and a cool down mode. Stainless steel doors with a glass window or a solid door swing 135° for easy one handed operation.



DESIGNED & BUILT IN USA
PROFESSIONAL COOKING EQUIPMENT

A70711 RevA 10242023

AMERICAN RANGE®

A  Company

13592 Desmond St Pacoima CA 91331
T. 818.897.0808 Toll Free: 888.753.9898
www.AmericanRange.com

MAJESTIC GAS STANDARD DEPTH CONVECTION OVEN

MSD-1HE

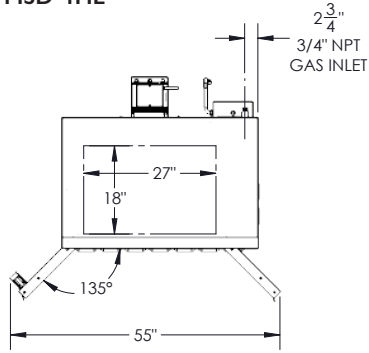

TOP VIEW

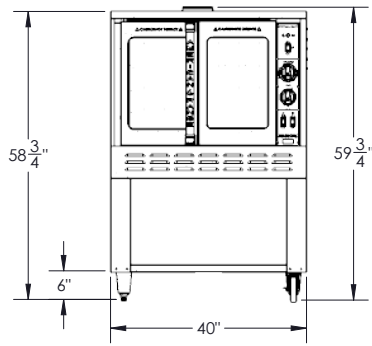

FRONT VIEW

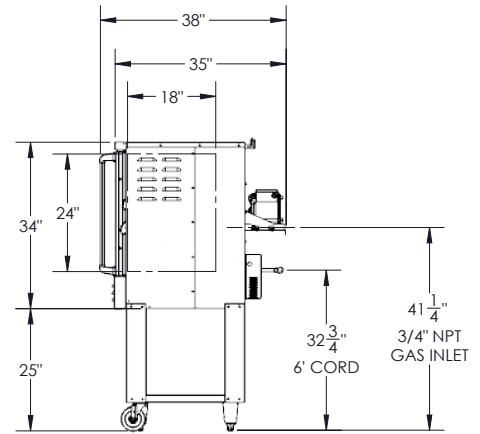

SIDE VIEW

MSD-2HE

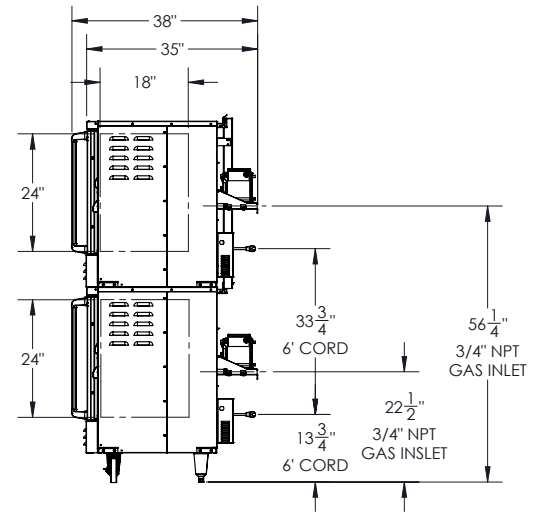
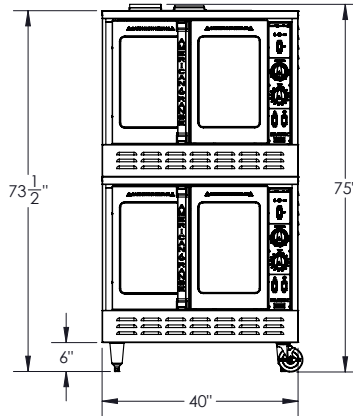
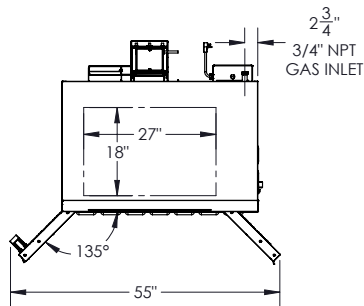

MODEL	WIDTH (MM)	DEPTH (MM)	HEIGHT (MM)	BTU	(KW)	BURNERS	Ship Weight*	
							LBS	(KG)
MSD-1HE	40" (1016)	38" (966)	59 3/4" (1518)	54,000	(18)	2	585	(265)
MSD-2HE	40" (1016)	38" (966)	75" (1905)	108,000	(35)	4	1100	(500)

Add two letter code to model number for door preference
 Door options: GG- Two glass doors, GR- Glass door, right, GL- Glass door, left

Installation Instructions:

- Ovens must be installed in accordance with local codes or in their absence with the
- 1. National Fuel Gas Code: ANSI Z223.1; CAN/CGA-B149.1 Natural Fuel and Propane Installation Code, as applicable. Compliance with codes is the responsibility of the Owner and Installer.
- 2. An adequate ventilation system is required. Refer to National Fire Protection Association Standard No. 96, Standard for Ventilation Control and Fire Protection of Commercial Cooking Operations
- 3. This appliance is intended for commercial use. NOT intended for Residential Use.
- 4. Specify installation elevation if above 2000 feet (610m)
- 5. Please specify gas type when ordering
- 6. GAS INLET SIZE (All Models): One 3/4" NPT gas connections provided at rear. One 3/4" NPT gas pressure regulators are provided and must be installed (by others) when unit is connected to gas supply.
- 7. COMBUSTIBLE WALL CLEARANCES:
 For use only on non-combustible floors. Legs or casters are required, or 2" (51) overhang is required when curb mounted. Clearance from non-combustible walls is 0". When unit is placed next to combustible walls, clearances must exceed 12" (305) from sides, and 4" (102) from rear.

CONVECTION OVEN ELECTRICAL		
VOLTAGE	PHASE	AMPS
120	1	4

MANIFOLD PRESSURE		
NATURAL GAS	PROPANE GAS	MANIFOLD SIZE
5.0" W.C.	10.0" W.C.	3/4" (19MM)

NMFFCODE: 25970-2 Class: 85

*Shipping weight includes packaging and is approximate.

15 amps three prong cord provided



A70711 RevA 10242023



13592 Desmond St Pacoima CA 91331
 T. 818.897.0808 Toll Free: 888.753.9898
 www.AmericanRange.com