

## GAS CONVECTION OVEN

GAS TYPE:  NATURAL  LP



M  M DBL

### STANDARD FEATURES

- Bakery depth models 75,000 BTU/hr. total heat output per oven
- All stainless steel front, sides, and top
- 50/50 dependent double doors
- 135° degree door swing
- Oven doors standard with two glass doors (GG) or optional two solid doors (SS)
- Porcelainized oven interior for easy cleaning
- Five chrome racks with 12 position chrome rack guides
- Holds up to (5) 18" x 26" sheet pans left to right or front to back
- Electronic spark igniter
- 1/2 H.P. two speed oven blower motor with maximum of 9 amp draw. Includes power cord
- Oven cool switch for rapid cool down
- Burner "on" light
- 1 hour timer
- Thermostat control from 200°F to 500°F (93°C to 260°C)
- Single or double units come with either 6" legs or casters
- Two year limited warranty, parts, and labor

### OPTIONAL FEATURES

- Cooling/storage racks
- Seismic feet
- Direct vent adapter



**Model Shown M DBL**  
(Bakery depth)

### DESCRIPTION

American Range, model M single or M DBL double, bakery depth convection oven with 75,000 BTU/hr., temperature range from 200°F to 500°F. A half horsepower fan offers low and high speed fan options for baking and roasting. Porcelainized oven cavity includes 5 racks and 12 position rack guide to accommodate 18" x 26" sheet pan (1) or 12" x 20" hotel pan (2) per rack. The oven includes a 1 hour timer and a cool down mode. Oven standard with dependent glass doors and a 135° degree swing. Single or double units come standard with either 6" legs or casters.



# MAJESTIC GAS BAKERY DEPTH CONVECTION OVEN

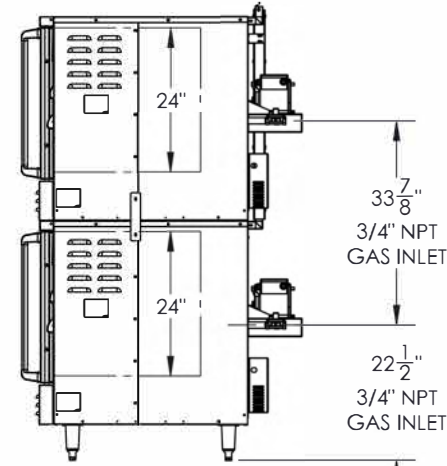
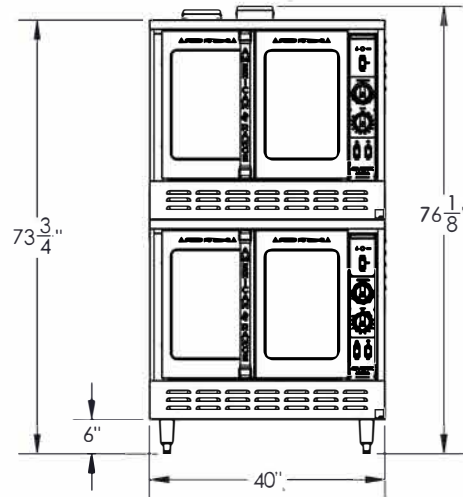
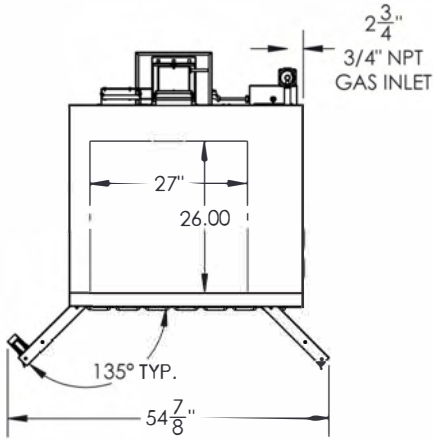
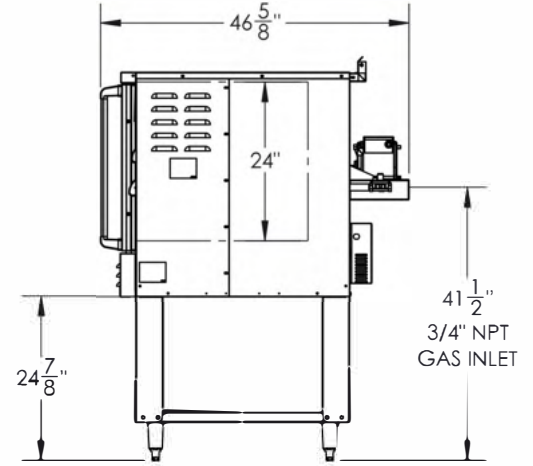
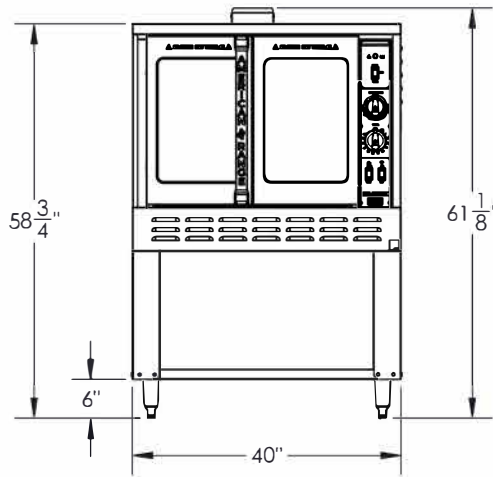
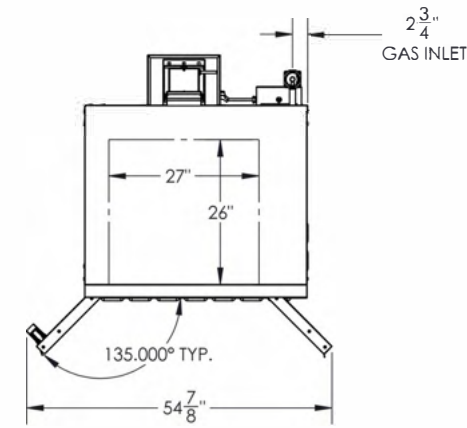

MODEL	WIDTH (MM)	DEPTH (MM)	HEIGHT (MM)	BTU/hr.	(KW)	BURNERS	Ship Weight*	
							LBS	(KG)
M	40" (1016)	46" 5/8 (1184)	61" 1/8 (1553)	75,000	(26)	2	640	(291)
M DBL	40" (1016)	46" 5/8 (1184)	76" 1/8 (1934)	150,000	(52)	4	1280	(582)

Add two letter code to model number for door preference  
 Door options: GG- Two glass doors, SS- Two solid doors

**Installation Instructions:**

Ovens must be installed in accordance with local codes or in their absence with the

1. National Fuel Gas Code: ANSI Z223.1; CAN/CGA-B149.1 Natural Fuel and Propane Installation Code, as applicable. Compliance with codes is the responsibility of the Owner and Installer.
2. An adequate ventilation system is required. Refer to National Fire Protection Association Standard No. 96, Standard for Ventilation Control and Fire Protection of Commercial Cooking Operations
3. This appliance is intended for commercial use. NOT intended for Residential Use.
4. Specify installation elevation if above 2000 feet (610m)
5. Please specify gas type when ordering
6. GAS INLET SIZE (All Models): One 3/4" NPT gas connections provided at rear. One 3/4" NPT gas pressure regulators are provided and must be installed (by others) when unit is connected to gas supply.
7. COMBUSTIBLE WALL CLEARANCES

For use only on non-combustible floors. Legs or casters are required, or 2" (51) overhang is required when curb mounted. Clearance from non-combustible walls is 0". When unit is placed next to combustible walls, clearances must exceed 12" (305) from sides, and 4" (102) from rear.

CONVECTION OVEN ELECTRICAL		
VOLTAGE	PHASE	AMPS
120	1	4

MANIFOLD PRESSURE		
NATURAL GAS	PROPANE GAS	MANIFOLD SIZE
5.0" W.C.	10.0" W.C.	3/4" (19MM)

\*Shipping weight includes packaging and is approximate.

15 amps three prong cord provided

