

## ELECTRIC CONVECTION OVEN



■ ME-1

■ ME-2

### STANDARD FEATURES

- 12 kW 208/240 Volt Bakery Depth (ME) units
- All stainless steel front, sides, and top
- 50/50 dependent double doors
- 135° degree door swing
- Oven doors standard with two glass doors (GG) or optional two solid doors (SS)
- Porcelainized oven interior for easy cleaning
- Five chrome racks with 12 position chrome rack guides
- Oven cavity accommodates a full size sheet pan side-to-side on bakery depth models
- Electronic spark igniter
- 1/2 H.P. two speed oven blower motor with maximum of 9 amp draw
- Oven cool switch for rapid cool down
- Burner "on" light
- 1 hour timer
- Thermostat control from 200°F to 500°F (93°C to 260°C)
- Single or double units come with either 6" legs or casters
- Two year limited warranty, parts, and labor

### OPTIONAL FEATURES

- Cooling/storage racks
- Seismic feet
- 208/240 V motor and/or transformer
- Direct vent adapter



**Model Shown ME-1**  
(Bakery Depth)

### DESCRIPTION

American Range, model ME-1 single or ME-2 double, bakery depth convection oven with 12 kW 208/240 volts, temperature range from 200°F to 500°F. A half horsepower fan offers low and high speed fan options for baking and roasting. Porcelainized oven cavity includes a 12 position rack guide to accommodate five chrome racks which will hold 18" x 26" sheet pan (1) horizontally or 12" x 20" hotel pan (2) per rack. The oven includes a 1 hour timer and a cool down mode. Oven standard with dependent glass doors and a 135° degree swing. Single or double units come standard with either 6" legs or casters.



# MAJESTIC ELECTRIC BAKERY DEPTH CONVECTION OVEN

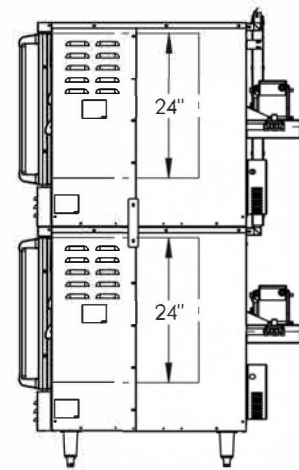
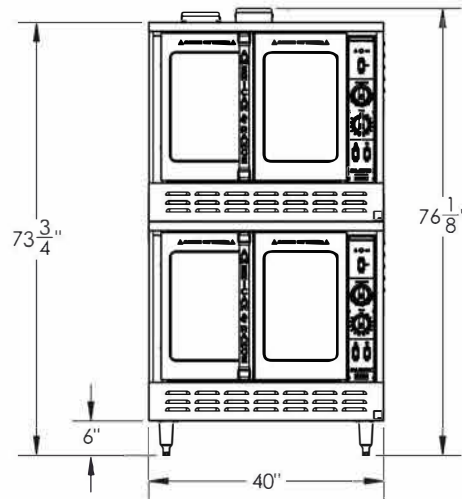
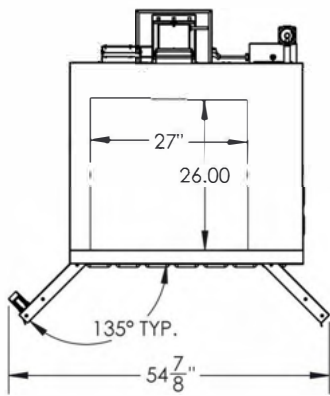
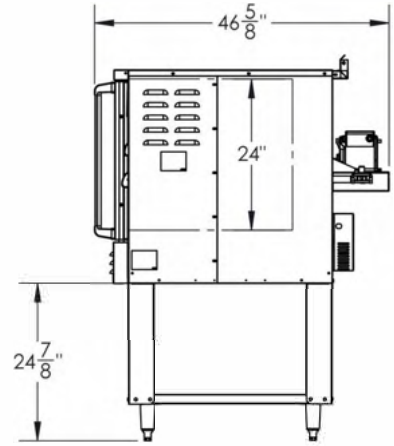
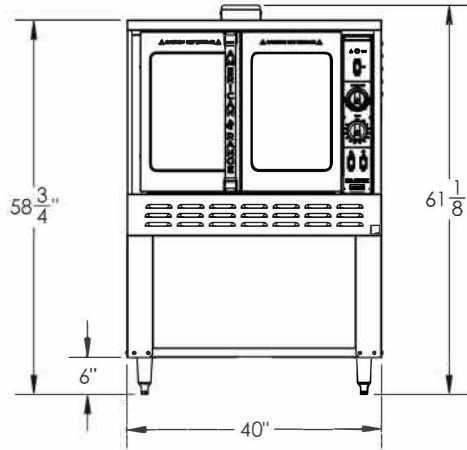
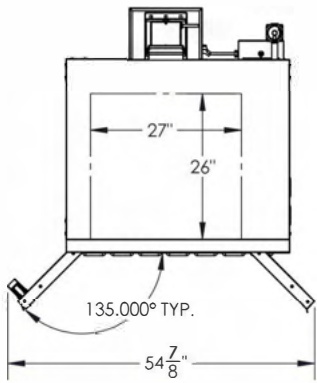

MODEL	WIDTH (MM)	DEPTH (MM)	HEIGHT (MM)	ELEMENTS	(KW)	Ship Weight*	
						LBS	(KG)
ME-1	40" (1016)	46" 5/8 (1184)	61" 1/8 (1553)	3	(12)	640	(291)
ME-2	40" (1016)	46" 5/8 (1184)	76" 1/8 (1994)	6	(24)	1280	(582)

Add two letter code to model number for door preference  
 Door options: GG- Two glass doors, SS- Two solid doors

## ELECTRICAL (Specify voltage and phase when ordering)

1 Phase:

- 208VAC, 50A, 1 Phase, 60 Hz
  - 240VAC, 50A, 1 Phase, 60 Hz
- Plug and cord not included.

3 Phase:

- 208VAC, 30A, 3 Phase, 60 Hz
- 240VAC, 30A, 3 Phase, 60 Hz

## COMBUSTIBLE WALL CLEARANCES:

For use only on non-combustible floors. Legs or casters are required, or 2" (51) overhang is required when curb mounted. Clearance from non-combustible walls is 0". When unit is placed next to combustible walls, clearances must exceed 12" (305) from sides, and 4" (102) from rear.

Commercial cooking equipment requires an adequate ventilation system. For additional information, refer to the National Fire Protection Association's standard.

NFPA96 "Vapor Removal from Cooking Equipment."  
 (NOTE: For North America only)

Shipping weight includes packaging and is approximate.

