

AMERICAN RANGE®

A  Company

Project _____

Item # _____

Quantity _____

AF-75 FRYER

GAS TYPE: NATURAL LP



AF-75

STANDARD FEATURES

- All stainless steel front and sides
- Heavy gauge stainless steel tank
- Burners rated at 40,000 BTU/hr. each
- Millivolt control system with 100% safety shut off
- Thermostatic control with 200°F to 400°F range
- 1-1/4" full port drain valve
- 6" legs or optional casters
- 18" x 18" frying area. 75 pounds oil capacity
- Two year limited warranty, parts and labor

AVAILABLE OPTIONS

- Stainless steel tank cover
- Four casters front two with locking brakes
- Stainless steel Splash Guard
- Joiner Strip: Connects two fryers and prevents oil from getting in between the fryers or drain station



Model Shown AF-75
Shown with optional casters

DESCRIPTION

American Range, 75 pound fryer, model AF-75. All stainless steel front and sides, with heavy gauge stainless steel tank and rated at 160,000 BTU/hr. Standard Millivolt control system with 100% safety shut off and Thermostatic control with a temperature range of 200°F to 400°F. 1-1/4" full port drain valve for easy cleaning.



A70162 RevC 09302024

AMERICAN RANGE®

A  Company

13592 Desmond St Pacoima CA 91331
T. 818.897.0808 Toll Free: 888.753.9898
www.AmericanRange.com

AF-75 FRYER

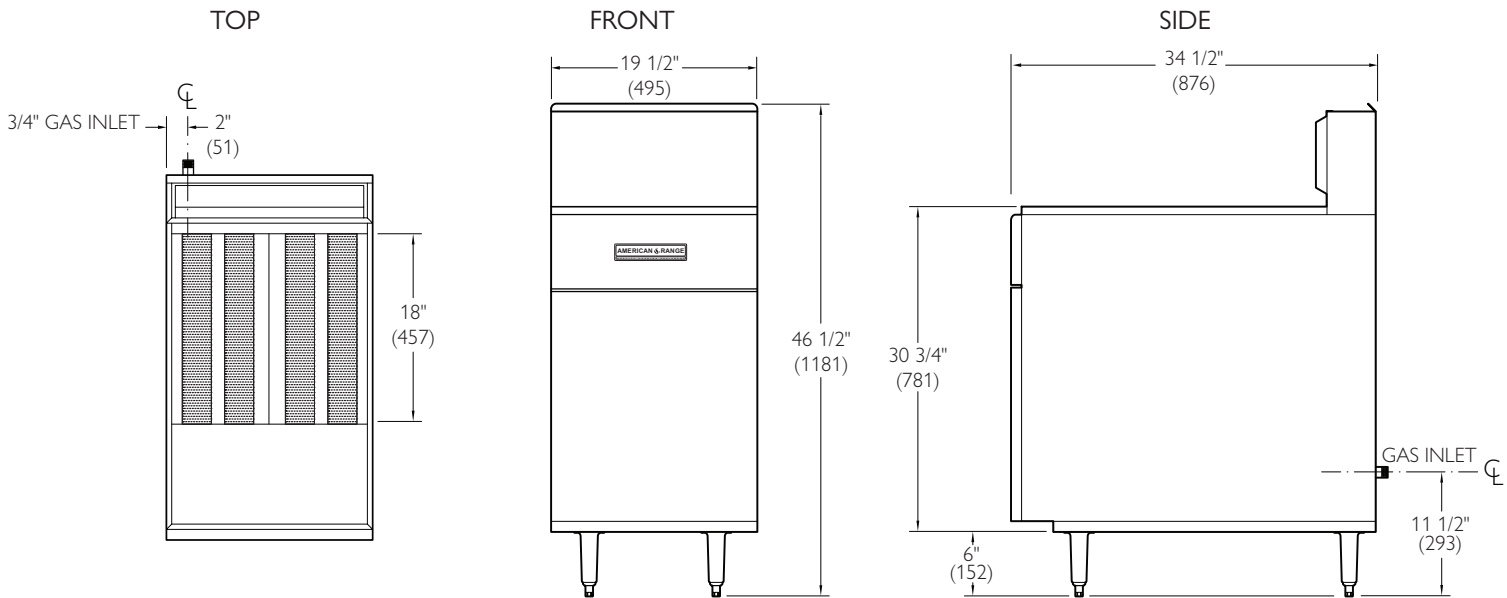

MODEL	WIDTH (MM)	DEPTH (MM)	HEIGHT (MM)	BURNERS	BTU	(kW)	Shipping Weight*	
							LBS	(KG)
AF-75	19 1/2" (495)	34-1/2" (876)	46-1/2" (1181)	4	160,000	(47)	198	(90)

- (A99458) Stainless steel tank cover
- (A99342 left) Stainless steel Splash Guard
- (A99343 right) Stainless steel Splash Guard
- (A99413) Joiner Strip: Connects two fryers and prevents oil from getting in between the fryers or drain station

Specify type of gas and altitude if over 2000 feet.

Please specify gas type when ordering.

NATURAL GAS	MANIFOLD PRESSURE	
	PROPANE GAS	MANIFOLD SIZE
5.0" W.C.	10.0" W.C.	3/4" (19MM)

NMFCCODE: 25970-2 Class: 85

*Shipping weight includes packaging and is approximate.

COMBUSTIBLE WALL CLEARANCES:

For use only on non-combustible floors. Legs or casters are required, or 2" (51) overhang is required when curb mounted. Clearance from non-combustible walls is 0". When unit is placed next to combustible walls, clearances must exceed 12" (305) from sides, and 4" (102) from rear.

Commercial cooking equipment requires an adequate ventilation system. For additional information, refer to the National Fire Protection Association's standard.

NFPA96 "Vapor Removal from Cooking Equipment." (NOTE: For North America only)

American Range is a quality manufacturer of commercial cooking equipment. Due to continuing product improvements, these specifications are subject to change without prior notice.



13592 Desmond St Pacoima CA 91331
T. 818.897.0808 Toll Free: 888.753.9898
www.AmericanRange.com