

AMERICAN RANGE®

A  Company

Project _____

Item # _____

Quantity _____

AF-25 FRYER

GAS TYPE: NATURAL LP



AF-25 AF25-DS AF-25/25

STANDARD FEATURES

- All stainless steel front and sides.
- Heavy gauge stainless steel tank.
- Burner rated at 80,000 BTU/hr.
- Millivolt control system with 100% safety shut off.
- Thermostatic control with 200°F to 400°F range.
- 1-1/4" full port drain valve.
- 6" legs or optional casters.
- 8-3/4" x 14" frying area. 25 pounds oil capacity.
- Two year limited warranty, parts and labor.
- 25-pound fryer with a dump station is a perfect solution for a small fry station
- 25-pound fryer without a dump station is also available. Note fryer needs to be mounted for stability.
- Tube fryer with even heating
- Heats oil quickly resulting in less absorption and better-tasting food.
- Tube joints are precision-welded onto specially drawn fry pot openings to prevent leaks
- 5 year tank warranty

AVAILABLE OPTIONS

- Stainless steel tank cover.
- Four casters front two with locking brakes.
- Stainless steel Splash Guard (easily removable without tools).
- Joiner Strip: Connects two fryers and prevents oil from getting in between the fryers or drain station.
- Heat lamp.

*Unit comes with two legs; fryer must be anchored for stability.



Model Shown AF-25*

Must be anchored for stability.



Model Shown AF25-DS

Shown with optional casters.

DESCRIPTION

American Range, 25 pound fryer, model AF-25. All stainless steel front and sides, with heavy gauge stainless steel tank and rated at 80,000 BTU/hr. Standard Millivolt control system with 100% safety shut off and Thermostatic control with a temperature range of 200°F to 400°F. 1-1/4" full port drain valve for easy cleaning.



DESIGNED & BUILT IN USA
PROFESSIONAL COOKING EQUIPMENT

AMERICAN RANGE®

A  Company

13592 Desmond St Pacoima CA 91331
T. 818.897.0808 Toll Free: 888.753.9898
www.AmericanRange.com

AF-25 FRYER

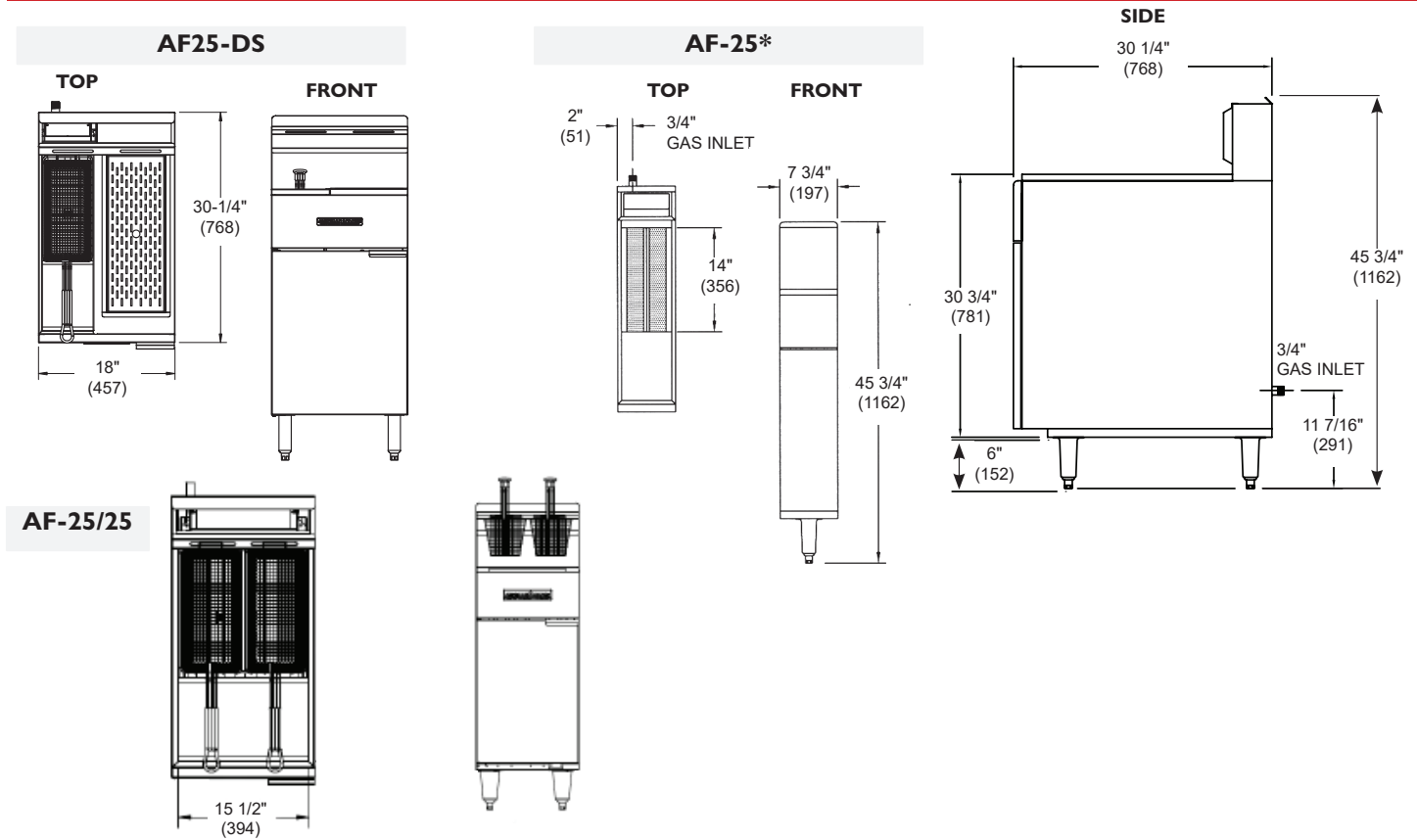

MODEL	WIDTH (MM)	DEPTH (MM)	HEIGHT (MM)	COOKING AREA	BTU	(kW)	Shipping Weight*	
							LBS	(KG)
AF-25	7 3/4" (197 mm)	30-1/4" (768 mm)	45-3/4" (1162 mm)	(1) 8 3/4"x 14" (222 mm x 356 mm)	80,000	(23)	99	(45)
AF25-DS	18" (457 mm)	30-1/4" (768 mm)	45-3/4" (1162 mm)	(1) 8-3/4"x 14" (222 mm x 356 mm)	80,000	(23)	198	(90)
AF-25/25	15 1/2" (394 mm)	30-1/4" (768 mm)	45-3/4" (1162 mm)	(2) 8-3/4"x 14" (222 mm x 356 mm)	160,000	(47)	198	(90)

- (A99456) Stainless steel tank cover.
- (A99197 left) Stainless steel Splash Guard (easily removable without tools).
- (A99198 right) Stainless steel Splash Guard (easily removable without tools).
- (A99397) Joiner Strip: Connects two fryers and prevents oil from getting in between the fryers or drain station.

*Unit comes with two legs; fryer must be anchored for stability.

NATURAL GAS	MANIFOLD PRESSURE	
	PROPANE GAS	MANIFOLD SIZE
5.0" W.C.	10.0" W.C.	3/4" (19MM)

NMFCODE: 25970-2 Class: 85

*Shipping weight includes packaging and is approximate.

HEAT LAMP		
VOLTAGE	PHASE	AMPS
120	1	4

15 amps three prong cord provided

American Range is a quality manufacturer of commercial cooking equipment. Due to continuing product improvements, these specifications are subject to change without prior notice.

Specify type of gas and altitude if over 2000 feet.

Please specify gas type when ordering.

COMBUSTIBLE WALL CLEARANCES:

For use only on non-combustible floors. Legs or casters are required, or 2" (51) overhang is required when curb mounted. Clearance from non-combustible walls is 0". When unit is placed next to combustible walls, clearances must exceed 12" (305) from sides, and 4" (102) from rear.

Commercial cooking equipment requires an adequate ventilation system. For additional information, refer to the National Fire Protection Association's standard.

NFPA96 "Vapor Removal from Cooking Equipment." (NOTE: For North America only)



13592 Desmond St Pacoima CA 91331
T. 818.897.0808 Toll Free: 888.753.9898
www.AmericanRange.com