

## COUNTERTOP RADIANT CHARBROILER

GAS TYPE:  NATURAL  LP



- ARSRB-12       ARSRB-36
- ARSRB-24       ARSRB-60
- ARSRB-48
- ARSRB-72

### STANDARD FEATURES

- Stainless steel front, sides, landing ledge, and grease tray
- 15,000 BTU/hr. burners with cast iron radiants spaced 6" apart with individual burner controls
- Standing pilots ignition system
- Heavy duty cast iron reversible grates provide attractive grill marks
- Heat deflectors to drive heat up for better cooking performance, and to keep the grease pan cool
- Stainless steel 3 3/4" side splash, and 4" back splash
- 4" adjustable legs included
- Two year limited warranty, parts, and labor

### AVAILABLE OPTIONS

- Stainless steel stand
- Swivel casters (set of four – two with front brakes)



Model Shown ARSRB-36

### DESCRIPTION

American Range ARSRB Series Charbroiler  
 Countertop Gas Charbroiler American Range No. \_\_\_\_\_.  
 Stainless steel front, sides, landing ledge, and grease tray. 12 9/16" cooking height with 4" adjustable inset legs. 15,000 BTU/hr. burners spaced 6" apart with individual burner controls and a standing pilot ignition system. Heavy duty cast iron reversible grates provide attractive grill marks. Heat deflectors to drive heat up for better cooking performance and to keep the grease pan cool. 8" stainless steel back splash and 3 3/4" side splash. 3/4" rear gas connection and gas pressure regulator. Select natural gas or liquid propane. Two year limited warranty for parts and labor.



# COUNTERTOP RADIANT CHARBROILER

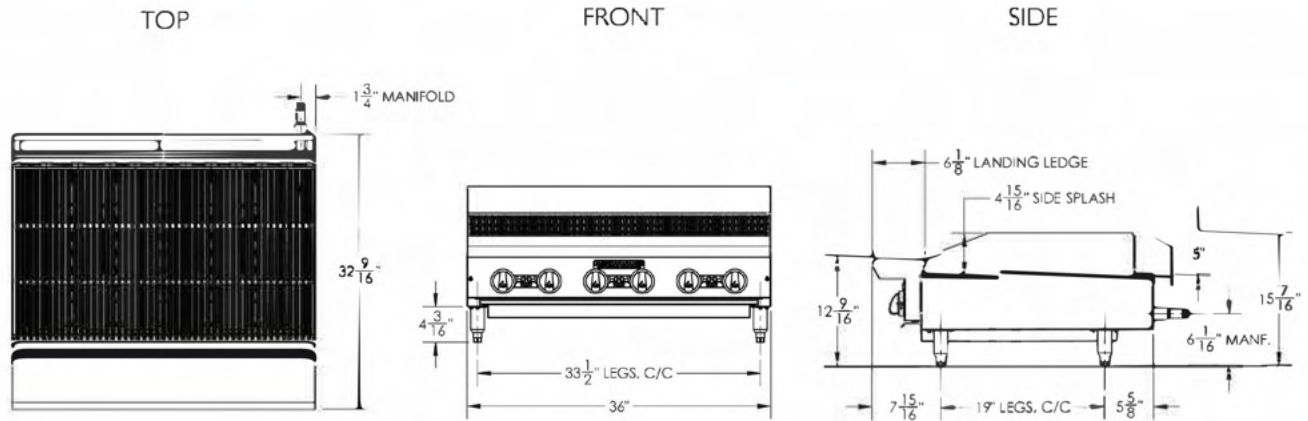

Model	Width (mm)	Depth (mm)	Height (mm)	Burners	BTU/hr.	Lbs & KG
ARSRB-12	24" (305)	30" (762)	12 9/16" (319)	2	30,000	165 (74.8)
ARSRB-24	24" (610)	30" (762)	12 9/16" (319)	4	60,000	210 (95.3)
ARSRB-36	36" (914)	30" (762)	12 9/16" (319)	6	90,000	285 (129.2)
ARSRB-48	48" (1219)	30" (762)	12 9/16" (319)	8	120,000	363 (164.7)
ARSRB-60	60" (1524)	30" (762)	12 9/16" (319)	10	150,000	400 (181.4)
ARSRB-72	72" (1829)	30" (762)	12 9/16" (319)	12	180,000	560 (254.0)

- Specify type of gas and altitude if over 2000 feet.
- Please specify gas type when ordering.

## COMBUSTIBLE WALL CLEARANCES:

For use only on non-combustible floors. Legs or casters are required, or 2" (51) overhang is required when curb mounted. Clearance from non-combustible walls is 0". When unit is placed next to combustible walls, clearances must exceed 12" (305) from sides, and 4" (102) from rear.

Commercial cooking equipment requires an adequate ventilation system. For additional information, refer to the National Fire Protection Association's standard.

NFPA96 "Vapor Removal from Cooking Equipment."

(NOTE: For North America only)

Subject to change without notice

\*Shipping weight includes packaging and is approximate.

MANIFOLD PRESSURE		
NATURAL GAS	PROPANE GAS	MANIFOLD SIZE
5.0" W.C.	10.0" W.C.	3/4" (19MM)

