

# AMERICAN RANGE®

A  Company

Project \_\_\_\_\_

Item # \_\_\_\_\_

Quantity \_\_\_\_\_

## TUBE FRYER

GAS TYPE:  NATURAL  LP



### AF-35/50

#### STANDARD FEATURES

- All stainless steel front and sides
- Heavy gauge stainless steel tank
- Three burner tube fryer rated at 120,000 BTU/hr. each
- Millivolt control system with safety shut off
- Thermostatic control with 200°F to 400°F range
- Large cool zone below the tubes hold in particles
- 1-1/4" full port drain valve for easy and safe oil removal
- 6" legs or optional casters
- Two year limited warranty, parts and labor (Five year tank warranty)

#### AVAILABLE OPTIONS

- Stainless steel tank cover
- Four casters front two with locking brakes
- Stainless steel splash guard, left or right
- Joiner Strip: Connects two fryers and prevents oil from getting in between the fryers or drain station



**Model Shown AF-35/50**

Shown with optional casters

#### DESCRIPTION

##### **American Range, 50 pound fryer, model AF-35/50.**

All stainless steel front and sides, with heavy gauge stainless steel tank and rated at 120,000 BTU/hr., standard millivolt control system with 100% safety shutoff. Thermostatic control with a temperature range of 200°F to 400°F. 1-1/4". A large cool zone below the tubes holds in particles to reduce flavor transfer. Full pot drain valve for easy and safe oil removal. Two-year limited warranty, parts, and labor. Five year tank pro-rated warranty.



# AMERICAN RANGE®

A  Company

13592 Desmond St Pacoima CA 91331  
T. 818.897.0808 Toll Free: 888.753.9898  
[www.AmericanRange.com](http://www.AmericanRange.com)

# TUBE FRYERS

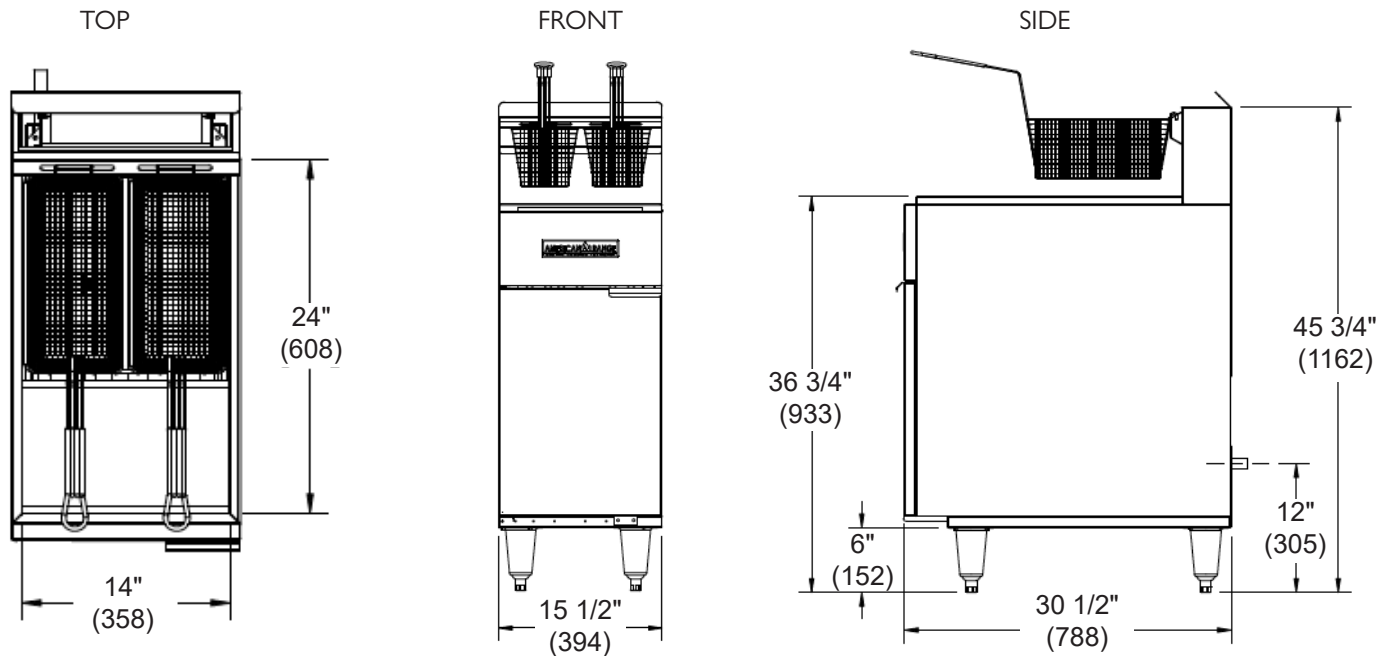

MODEL	WIDTH (MM)	DEPTH (MM)	HEIGHT (MM)	BURNERS	BTU	(KW)	Shipping Weight*	
							LBS	(KG)
AF-35/50	15 1/2" (394)	30-1/2" (788)	45-3/4" (1162)	3	120,000	(22)	150	(68)

Specify type of gas and altitude if over 2000 feet.

### Optional Accessories:

- 4- 6" plate casters (A35117)
- Tank Cover (A99415)
- Splash Guard, left (A99251)
- Splash Guard, right (A99252)
- Joiner Strip, (A99412)

NATURAL GAS	MANIFOLD PRESSURE	
	PROPANE GAS	MANIFOLD SIZE
5.0" W.C.	10.0" W.C.	3/4" (19MM)

American Range is a quality manufacturer of commercial cooking equipment. Due to continuing product improvements, these specifications are subject to change without prior notice.

### COMBUSTIBLE WALL CLEARANCES:

For use only on non-combustible floors. Legs or casters are required, or 2" (51) overhang is required when curb mounted. Clearance from non-combustible walls is 0". When unit is placed next to combustible walls, clearances must exceed 12" (305) from sides, and 4" (102) from rear.

Commercial cooking equipment requires an adequate ventilation system. For additional information, refer to the National Fire Protection Association's standard.

NFPA96 "Vapor Removal from Cooking Equipment." (NOTE: For North America only)

NMFCCODE: 25970-2 Class: 85

\*Shipping weight includes packaging and is approximate.



A70612 RevB 09302024



13592 Desmond St Pacoima CA 91331  
T. 818.897.0808 Toll Free: 888.753.9898  
www.AmericanRange.com